



Amadeo X-ray Systems

Mobile X-ray imaging in a new dimension:

The **Amadeo M** systems – wireless or wired, also suitable for field work



Compact and light,
shockproof
and splash
resistant



For use on ships, yachts and oil rigs,



... in ambulances and hospitals as a mobile bedside X-ray system or in the casualty department,



... for disaster management and casualty treatment in container or tent based ambulances or rescue units,



... in prisons, for military purposes and for health care in developing countries,



... in inaccessible areas, in laboratories and scientific stations in remote parts of the world

Digital X-ray imaging with a compact mobile solution for outpatient and stationary use

The **Amadeo M** series design combines necessary functions with elements of bionic form. The result is a medical product that conveys a harmonious combination of X-ray technology, functionality and flair to the user and patient.

Due to its very low overall weight and its compact design, the system is very versatile in its use and easy to transport. Modern X-ray technology can be applied wherever patients cannot be taken to a hospital for quick radiological diagnosis. Therefore the **Amadeo M** system is also used successfully in various military emergency situations.

The system benefits from an optimally adjusted weight-size-performance ratio. The **Amadeo M** system includes, depending on the version, all the necessary components such as X-ray detector, X-ray generator and image processing workstation including a globally used software package with a practical X-ray positioning guide for correct adjustment.

The **Amadeo M** was specially developed for doctors and medical services in remote and inaccessible areas, medically oriented aid organisations as well as ships and oil rigs. Due to its excellent mobility, safe handling can be guaranteed even in confined hospital rooms and lifts. It can even be transported via staircases.

The system is CE certified and approved for any human X-rays. The **Amadeo M** system can be packed in a special shockproof transport box and may even be dropped by parachute.



Benefits

Digital X-ray imaging with the **Amadeo M** systems

Light, mobile and highly versatile

The **Amadeo M** is a light yet robust portable X-ray system with integrated DR X-ray detector (except for the AX version). It has been designed to be ideally suited for use in the most varied conditions. It is also a reliable partner in difficult locations, for instance in deserts or confined spaces.

Benefit: Flexible and mobile use

Powerful and efficient

The **Amadeo M** is a very powerful X-ray system offering the full range of X-ray diagnostic imaging techniques for human patients.

Benefit: Mobile X-ray imaging from head to toe including thorax and abdomen

Light as a feather

The entire design follows the principles of mobility and lightweight construction with predominantly aluminium components, the use of modern plastics and some stainless steel components for parts under static stress.

Benefit: Form follows function, resulting in low weight.

Easy to operate

The **Amadeo M** X-ray system is very easy to clean. All electronic components are sealed to ensure safe transport. External cables have mostly been eliminated. An optional plastic transport box allows safe transportation and storage.

Benefit: Uncomplicated handling and maintenance

Quick setup

The system can be set up to be ready for use in less than two minutes.

Benefit: No time loss in emergency situations



Suitable
for CR and
DR systems

Top performance in terms of X-ray technology

Due to the system's excellent protective lead shield, the housing radiation leakage is minimal, reducing the controlled area during the X-ray process to as little as 1.5 m.

Benefit: No other radiation protection measures are required outside the small controlled area

Reliable

Even under extreme climatic conditions such as high humidity or large temperature fluctuations, the **Amadeo M** X-ray system is a reliable partner. Therefore it is used successfully by numerous medical services and military units, on research ships, oil rigs etc.

Benefit: Professional work is possible even under extraordinary climatic conditions.

Unrivalled package

The new Amadeo M systems are unrivalled on the global market in terms of performance, size, weight and compact design, providing an optimal integrated operational concept to produce excellent X-ray images under the most varied conditions.

Benefit: Brilliant X-ray images, fast und uncomplicated

Fast cycle times

In relation to its size, the **Amadeo M** performs a very high shot frequency due to the high output power of the X-ray tube. Under full load it produces up to six images per minute – a leading performance for such units.

Benefit: Full performance at short exposure times

Timesaving when changing locations

A UPS (optional) maintains the PC's operating ability in case of short term change of location or power failure.

Benefit: The system does not have to be booted up again – the **Amadeo M** is immediately operational.

User friendly

The professional **dicomPACS® DX-R** acquisition software excels through an intuitive and well designed graphic user interface. Examinations are conveniently conducted at the monitor and any necessary adjustments of the X-ray parameters are automatically passed on to the generator.

Benefit: Only one user console is required for the entire system.



Specifications

Generator

- 6 kW HF generator with unsurpassed performance as a monoblock version → very service friendly
- 40 to 120 kV
- Guarantees a continuously high shot frequency rate at maximum performance (100 mA to 50 kV)
- Feasible cycle times are comparable to exposure times of large mobile or stationary systems
- Tube focus 1.2 x 1.2 mm
- Duty cycle at 60 : 1 → very high shot frequency rate at a high output performance of the X-ray tube assembly (up to 150 mAs, optional 220 mAs) – produces, for instance, up to 5 images per minute in lung screenings
- Interface for bidirectional communication between console station and generator for transmission of KV and mAs/sec values etc.
- Optional integrated DAP meter
- Particularly bright light field in the collimator → guarantees optimal

Electronics system box (for DR operation)

- Elegant design made of a UV resistant and sturdy polycarbonate exterior casing
 - Houses all the necessary electronic components such as the X-ray detector and the monitor
 - Optional: batteries (UPS) to maintain the PC's operating ability
 - in case of short term change of location or power failure
 - Integrated 19" HD multi touch monitor with superior brightness
 - Detector compartment for different types of detectors
 - Two external USB ports, wireless LAN, network connectivity RJ 45
 - Main switch for the complete system
 - High performance PC
- [The **Amadeo M-AX** version does not include any electronic components]

Stand

- Light construction, very stable and sturdy
- Large wheels with integrated drum brakes and castor wheels → allow easy handling on uneven floors and on open terrain
- Fluid motion tube adjustment through pneumatic struts for the height lift as well as the cantilever arm
- Maximum height setting: Approx. 195 cm from the floor while extending the X-ray tube to 100 cm → for working in a comfortable position at a patient's bed
- Flexible internal cable connections for safe, easy and clean operation as well as elegant looks – to meet even the highest hygiene demands in hospitals
- Effective storage and protection of all components for transport in an integrated electronics system box



PUSH

light conditions when positioning patients, even in the field

- Additional serial line laser available for X-ray tables
- Control display including 10 memory keys



only approx.
98 kg



System box for the DR version with integrated touchscreen monitor



System box for conventional X-ray imaging / for CR (M-AX version) to store the X-ray or CR cassettes



Software

Advantages of the professional *dicomPACS*[®]*DX-R* X-ray acquisition software

- Modern graphical user interface (GUI) adaptable to almost **any language**
- Capture of patient data via **DICOM Worklist, BDT/GDT, HL7** or other protocols – data may also be captured manually
- Use of **DICOM Procedure Codes** for the transfer of all relevant examination data directly from the connected patient management system (HIS/RIS)
- **Freely configurable** body parts with more than **200 projections** and numerous possible adjustments
- Safe and fast **registration of emergency patients**
- Allows the user to **switch between examinations** of a patient, for instance to avoid having to re-position the patient frequently
- Integrated **measuring, special image filters and many other tools** for measuring and image optimisation
- Allows the user to **subsequently add images** to an examination, even after that examination has already been completed
- Entry of recurring **examination procedures as macros**, e.g. thorax screenings
- **Fully integrated radiographic positioning guide** for each examination in human and veterinary medicine incl. comprehensive notes, photos, videos and correct X-ray images
- A single work station with installed *dicomPACS*[®]*DX-R* software may be upgraded by the following options (selection):
 - Tools for taking images of an entire leg (full spine) or an entire spine (**image stitching**)
 - Planning and working with **digital prostheses templates/operation planning**
 - Connection of several diagnostic monitors
 - Capturing additional patient and examination data and their freely configurable statistical evaluation



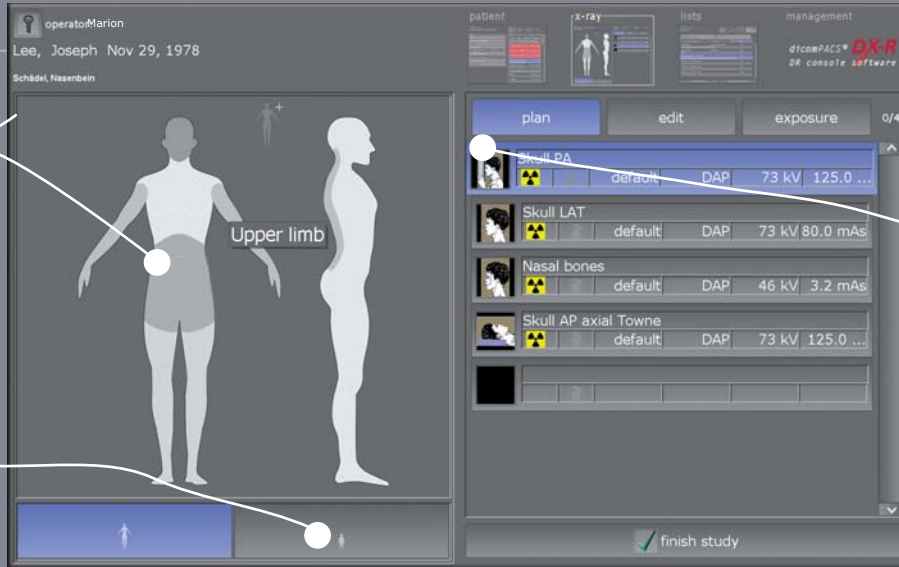

Chart for the planning of an individual X-ray job

Switch to the planning of X-ray jobs for children

The correct settings for adults and children at a mouse click

dicomPACS®DX-R job creation



Video with sound for the step by step positioning of the patient

Shows an example of a correct X-ray image

Presentation of helpful hints for the positioning of the patient, central beam, tips and tricks, frequent errors etc.

dicomPACS®DX-R radiographic positioning guide



Preview of the current X-ray image

Opens examples of inaccurate X-ray images with comments

Preview of the X-ray image and worklist in dicomPACS®DX-R

Software

The browser based viewer solution **dicomPACS® MobileView** for mobile terminals (optional)

dicomPACS® MobileView is a web-based viewer, that contains all the basic functions for viewing images. The viewing can take place virtually independent from the browser on mobile devices, such as an iPad. **dicomPACS® MobileView** offers doctors and nursing staff a previously unknown, mobile freedom in the workplace inside and outside of hospitals or practices, with the radiological image material available at all times.

Fields of application of **dicomPACS® MobileView**

dicomPACS® MobileView can be installed in addition to existing **dicomPACS®** diagnostic modules (diagnostic workstations). It is irrelevant whether the **dicomPACS® MobileView** software is used on a network PC (pure viewing workstation) or/ and on a mobile device.

Worldwide access to all image material is available via a network connection, e.g. VPN access via the internet, of the used mobile device to the central **dicomPACS®** system in the office or clinic.

Licensing model

dicomPACS® MobileView is used on a concurrent user licensing model. This means that the number of concurrent users is pre-defined.

The main advantages below at a glance:

- High flexibility through the use within various internet browsers, including Microsoft Internet Explorer, Mozilla Firefox, Google Chrome, Safari 5, Safari for iPad and Android browser Intuitive operation
- Supports the multi-touch operating technology (e.g. zoom in and out with two-fingers)
- Supports full screen mode
- Allows accessing the **dicomPACS® DX-R** or **dicomPACS®** database without any additional modules
- Allows playing series (e.g. ultrasound)
- High loading speed with modern streaming technology
- Uses concurrent user licenses

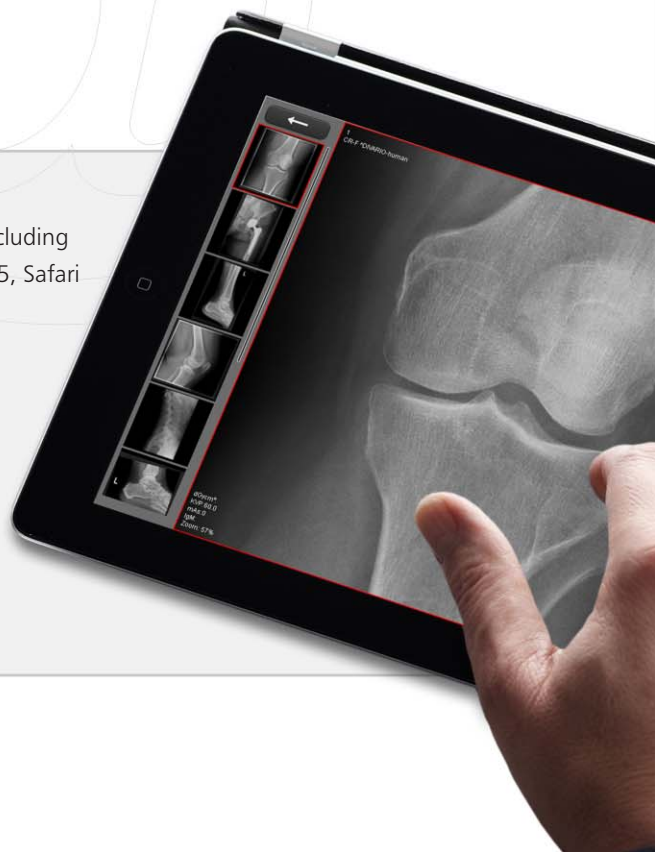

Automatic image processing for optimal quality of X-ray images with **dicomPACS® DX-R** image processing

- Perfect images at all times - generally **no adjustment** required
- Integrated software for **automatic image optimisation**
- Professional, **adaptable image processing** for each individual examination to obtain best possible image settings for the needs of each customer
- Due to specially developed processes, the image processing allows the user to **vary the X-ray settings on a large scale** while the image quality remains virtually the same (**possibility of reducing the dosage**)
- **Bones and soft tissue** in one image - this enables the user to significantly improve his diagnosis
- **Details of bones and microstructures are very easy to recognise**
- Noise suppression
- **Black mask** (automatic shutters)
- Automatic **removal of grid lines** when using fixed grids



Exposure with **standard** image processing



Exposure with **dicomPACS® DX-R** image processing

Software

ORCA - the Cloud-based archive solution for X-ray images and diagnostic (optional)

Even for state-of-the-art practices and hospitals, the rapidly rising data flood of digital images, diagnostic reports and other documents is becoming increasingly challenging. Current legislation demands safe and long-term storage of patient data which generally requires investing in expensive hardware infrastructure as well as maintenance and corresponding staff costs.

To this end, we developed the **ORCA** Cloud archiving solution, thus paving the way for cost-effective and safe Cloud-based data archiving in practices and clinics.

ORCA offers two application options:

- Safe, long-term archiving of patient data with intelligent usage of internal databases
- Communication platform (exchange of images and diagnostic reports) with colleagues and specialists or as an easy way to forward image data to patients (an alternative to creating patient CDs)

Data is **exclusively** archived on European servers with the relevant safety certificates.



Benefits of Cloud archiving through ORCA

Minimal expenditure: **ORCA** does not require investing in expensive infrastructure such as server and data cables.

Scalability: The amount of memory required when using **ORCA** is determined by the demand.

Long-term security: **ORCA** archives data on many individual European servers in professional and air-conditioned data centres. Server technology is continuously updated.

Accessibility: **ORCA** stands out by being highly accessible. Since data is saved with multiple redundancy, **ORCA** guarantees more continuity than a mere server solution.

Environmentally friendly: **ORCA** is sustainable – through the optimised use of resources and their distribution.

Location-independent: **ORCA** guarantees access to archived patient data - worldwide.

Simplicity: **ORCA** allows easy access to data from any computer – from your place of work, from the comfort of your home or from any other computer or tablet PC.

Stress-free: **ORCA** deals with everything – no need to struggle with loose network cables, removed hard drives or software problems.





Cloud based solution to access and archive images and diagnostic reports via the internet



 Amadeo M-DR

www.or-technology.com

Operation

Easy operation even for untrained staff

As a result of its simple operational concept and its reliability, the **Amadeo M** system is the ideal companion for the daily challenges in the medical field, even under adverse conditions and with changing staff.

The integrated **dicomPACS® DX-R** software assists the user in quickly creating optimal X-ray images. An integrated multimedia X-ray positioning guide explains the correct adjustment technique for each examination by means of illustrations and sound. Its simple and user friendly interface guides the user to the final X-ray image in easily understandable steps.

Recurring examination processes can be stored as macros (e.g. thorax screening), the automatic image optimising function is guaranteeing consistently perfect images. The availability of the user interface in various languages is another benefit.



Zooming in on the advantages of the **Amadeo M**:



The light field can be freely positioned with the rotatable collimator. This is a significant advantage when working on immobile, bedridden patients.



Made of high quality aluminium, even minute components of the system, such as contacts or connections, are suitable for outdoor use.



The sophisticated ergonomic design makes the **Amadeo M** system easy to operate.



Thanks to the well designed processes and support features the generator may be brought into any conceivable position without much effort.



Well thought-out details, such as the tape measure for measuring the film focus distance, support the user.



The brake mechanism ensures that the mobile system is stable during the X-ray process.

Alternative

Complete system as a combination of **Amadeo M-AX** system and **Leonardo** DR suitcase solution for additional options

The compact **Leonardo** DR suitcase solution is a fast and compact option for digital radiography in outpatient facilities. The combination with the **Amadeo M-AX** version is a perfect symbiosis for mobile direct digital X-ray imaging, in particular for outdoor use.

The combination of these two systems provides significant advantages, for example when several **Amadeo M-AX** systems are operated at different sites. The digital, light component can then be transported quickly and easily between sites, resulting in a substantial cost saving since it is not necessary to purchase several expensive complete systems.

The fact that the components are separate is another benefit: in case of repair only one unit has to be exchanged which saves both time and money.

Amadeo M-AX + Leonardo (upgrade to the DR version)

Advantages of the **Leonardo mini** suitcase solution – OR Technology's lightweight:

The very compact **Leonardo** DR mini system is housed in an attractive, robust suitcase. It can be set up on site in a few easy steps and is immediately operational.

It is currently the smallest and lightest suitcase with an unbeatable weight of only about 9.5 kg which can easily be transported by anyone.

It is comfortable as a shoulder bag and fits behind any car seat – saving space during transportation.

Small DR detectors can be kept directly in the suitcase. A stylish separate bag (optional) can be provided for transporting large detectors.



Amadeo M-AX (CR version)

CR cassettes which are housed in the compact system box of the **Amadeo** stand are used as image receivers. The only additional device required is a cassette reader.





Amadeo M-AX

only approx.
9,5 kg

Specifications

The high frequency generator in detail

Construction	Monoblock X-ray unit, high frequency technology (full bridge inverter system)
Output power	6 kW at 100 kV
Output in 2 kV steps	40 to 50 kV = 100 mA (max.) 52 to 60 kV = 80 mA (max.) 62 to 80 kV = 70 mA (max.) 82 to 100 kV = 60 mA (max.) 102 to 120 kV = 50 mA (max.)
X-ray tube	stationary anode
Focus	1.2 mm
mAs	0.4 - 143 mAs
Total filtration	3.64 mm Al (incl. collimator)
Inverter frequency	85 kHz
Line adjustment	fully automatic (Adjustment of the existing value from the voltage range 210 – 260 V to the "optimum value" for the basic parameters of the unit [230 – 240 V]. A warning light at the tube head indicates insufficient voltage.)
Line voltage	AC single phase 210 - 260 V; 50/60 Hz; 16 A
Overload protection	for high frequency transformer and X-ray tube
Collimator	100 Lux at FFD 100 cm
Dual laser pointer	2 laser diodes 8-30 V DC with protection class 1M
DAP equipment	ionisation chamber, display on the control panel (optional)
Remote control	layout similar to the control panel (without DAP display)
Serial interface	for connection to the digital radiography system

Additional features of the high frequency generator

- Digital display and setting of mAs/sec., kV
- LED display „X-RAY“, „READY“, „ERROR“
- 10 memory buttons
- Rotatable collimator
- Collimator light can be switched on via hand switch
- Acoustic and optical signal on release
- Tape measure for film focus distance
- Aluminium casing
- Slot system for compensation filter
- Guide rail for compensation filter



Accessories for portable X-ray imaging



Portable X-ray detector bracket VersariX (optional)

In addition to the **Amadeo M** X-ray solution OR Technology has developed a portable and compact detector bracket for room or wardrobe doors, walls etc. Especially suitable for use in old age homes, nursing care wards and in home care, this detector bracket offers enormous benefits. The normal heavy thorax stand is no longer required and will no longer need to be carried to the patient's bed. A room door is sufficient for taking almost any X-ray images of standing or sitting patients – while observing the relevant radiation protection regulations.

Mobile aids



Mobile wall stand and X-ray table (optional)

The **Amadeo M** systems can be complemented (optional) with a mobile wall stand and a mobile X-ray table. Both devices may be folded up or disassembled to save space for transport and reassembled easily within a few minutes.



Technical details

Service concept & operational requirements

Well thought out service concept:

- Maintenance friendly modular structure, consisting of only 3 main components
- In the absence of skilled staff, components can easily be disassembled and exchanged
- The system is virtually maintenance free – no need for hardware maintenance contracts
- Remote maintenance module provided as standard component keeps repair costs low. (not for AX version)
- 2 years guarantee (guarantee may be extended)

Operational requirements

Temperature range: 10 - 40° C

Humidity: 30 - 85%

Barometer: 70 - 106 kPa (700 - 1060 mbar)

In the case of an emergency, the **Amadeo M** system also operates in temperatures between 0° C and 45° C. In such cases, however, the system should not be operated under full load; up to 20 exposures per hour can be taken.



Dimensions of the X-ray system

 Amadeo M-Systeme

Overall weight: approx. 98 kg
(M-AX version 78 kg)

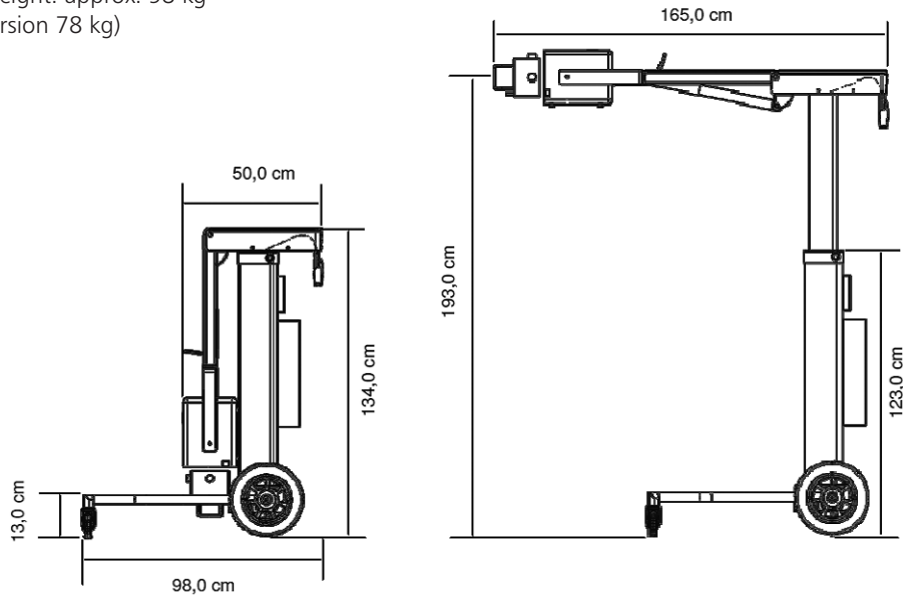

Dimensions of the transport box (optional)

Overall weight: approx. 47 kg

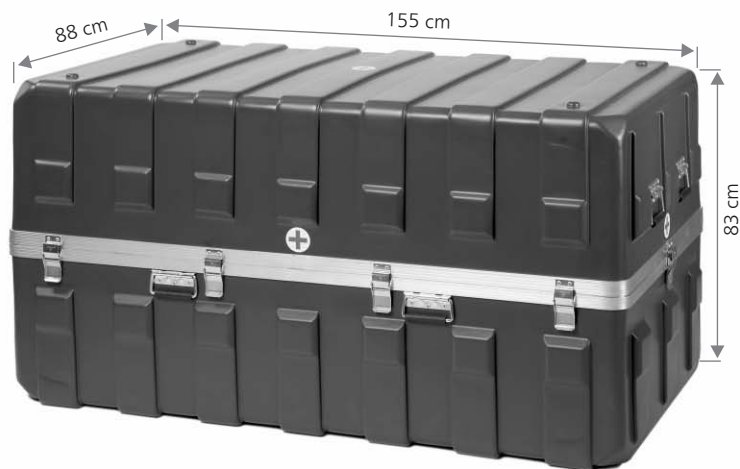







The **Amadeo M** system can be packed in this special shockproof transport box and even be dropped by parachute.

[no responsibility is taken for the correctness of the dimensions]

Scope of delivery

The Amadeo M systems include the following components as standard:

Components

Components	Amadeo M-DR mobile X-ray system with wired flat panel detector	Amadeo M-DRw mobile X-ray system with wireless flat panel detector	Amadeo M-AX mobile X-ray system for use with film/CR cassettes or existing DR system without generator control
Mobile X-ray unit <ul style="list-style-type: none"> Dimensions: 98 x 134 cm; with maximum height positioning: 165 x 193 cm Weight: depending on the version 	ca. 98 kg	ca. 98 kg	ca. 78 kg
Stand <ul style="list-style-type: none"> Light construction, very stable and sturdy Large wheels with integrated drum brakes and castor wheels – allow easy handling on uneven floors and on open terrain Fluid motion tube adjustment through pneumatic struts for the height lift as well as the cantilever arm Maximum height setting: approx. 195 cm from the floor while extending the X-ray tube to 100 cm Meets even the highest hygiene demands in hospitals 	✓	✓	✓
High frequency generator <ul style="list-style-type: none"> Efficient high frequency technology Short exposure times, reduced radiation exposure Monoblock X-ray unit in an aluminium casing Laser diodes for more precise positioning Collimator scale for adjusting the size of the light field Acoustic and optical signals Digital display and setting of mAs / sec., KV 10 memory buttons, adjustable dual laser pointer for SID LED display "X-RAY", "READY" und "ERROR" 	✓	✓	✓
Electronics system box <ul style="list-style-type: none"> UV resistant and sturdy polycarbonate casing Includes all the necessary electronic components such as X-ray detector and monitor Integrated 19" HD multi touch monitor and high performance PC Compartment for different detector types Main switch for the complete system Two external USB ports, wireless LAN, network connectivity 	✓	✓	-
Cassettes system box <ul style="list-style-type: none"> UV resistant and sturdy polycarbonate casing Cassette storage for conventional or CR cassettes in different sizes Main switch for the complete system 	-	-	✓
Operation via dicomPACS® DX-R acquisition console <p>Professional console software with modern graphic user interface with generator control, integrated X-ray positioning guide and basic software modules:</p> <ul style="list-style-type: none"> dicomPACS® DX-R DICOM Send SCU dicomPACS® DX-R DICOM Patient CD dicomPACS® DX-R Cognition Optimised Processing 	✓	✓	-



Components	Amadeo M-DR	Amadeo M-DRw	Amadeo M-AX	
<p>Flat panel detector 14" x 17" CsI</p> <p>Detector with excellent image quality and immediate image availability</p>	 <p>[Example]</p>	✓	-	-
<p>Flat panel detector 14" x 17" wireless</p> <p>Wireless X-ray imaging! Fits into an existing X-ray system without requiring modification (in conformity with the X-ray film cassette), fast-charging, long-life batteries</p>	 <p>[Example]</p>	-	✓	-
Optional components to upgrade the Amadeo M system:				
<p>DAP meter (Dose Area Product meter)</p>	●	●	●	
<p>Transport box</p> <ul style="list-style-type: none"> ▪ Made of durable plastic ▪ May even be dropped by parachute 		●	●	●
<p>Portable X-ray table, including transport box</p> <p>May be folded up or disassembled to save space during transport and reassembled easily within a few minutes.</p>		●	●	●
<p>Portable wall stand, including transport box</p> <p>May be folded up or disassembled to save space during transport and reassembled easily within a few minutes.</p>		●	●	●
<p>Mobile patient positioning table Z-Table</p> <ul style="list-style-type: none"> ▪ Floating table top ▪ Not height adjustable 		●	●	●
<p>Mobile stand for DR detectors and cassettes</p> <ul style="list-style-type: none"> ▪ Fast and precise positioning of detectors and cassettes ▪ Large wheels, low centre of gravity 		●	●	●
<p>Battery (UPS))</p> <p>To maintain the PC's operating ability in the case of a short term change of location or power failure.</p>	●	●	-	
<p>Mobile Leonardo mini DR suitcase solution</p> <ul style="list-style-type: none"> ▪ The compact suitcase solution is a fast and compact option for digital radiography in outpatient facilities. ▪ Weighing only approx. 9.5 kg, this is one of the lightest X-ray suitcases worldwide. 		-	-	●

Portfolio

Overview - products of OR Technology



Medici DR Systems

DR retrofits - digital upgrade set for existing X-ray systems incl. **dicomPACS®DX-R** acquisition software, also available for stationary and mobile X-ray machines



Leonardo DR Systems

DR suitcases - compact suitcase solutions for mobile and portable X-ray incl. **dicomPACS®DX-R** acquisition software



Amadeo X-ray Systems

Complete digital X-ray systems (incl. stand, bucky, generator, flat panel incl. **dicomPACS®DX-R** acquisition software etc.) as well as mobile and portable X-ray solutions



Divario CR Systems

CR solutions - CR systems for digital X-ray with cassettes incl. **dicomPACS®DX-R** acquisition software



X-ray Accessories

Accessories for X-ray
(e.g. radiation protection walls, gloves etc.)



dicomPACS®

Image management (PACS) - comprises acquisition, processing, diagnosis, transfer and archiving of image material



ORCA

Cloud-based archive solution - safe, long-term archiving of patient data with intelligent usage of internal databases, communication platform with colleagues and specialists and transfer of image data to patients



dicomPACS®DX-R
X-ray Acquisition Software

X-ray acquisition software [only for OEMs] - acquisition and diagnostic software for X-ray images from flat panels or CR systems



OR Technology
| Digital X-ray and
| Imaging Solutions

Info hotline: +49 381 36 600 600

OR Technology (Oehm und Rehbein GmbH)
18057 Rostock, Germany, Neptunallee 7c
Tel. +49 381 36 600 500, Fax +49 381 36 600 555
www.or-technology.com, info@or-technology.com

[Stamp of distribution partner]